

No.	Name	Q'ty	Description
1	Inlet Nozzle	1	Inlet Connection 10K FLG80A
2	Outlet Nozzle	1	Outlet Connection 10K FLG 80A
3	PreCooler	1	Hot Compressed Air-to-Cold Compressed Air HeatExchanger
4	Evaporator	1	Compressed Air-to-Refrigerant HeatExchanger
5	Air-Cooled Condenser	1	5HP, 0.1kW 6P x OD400 Fan x 2sets
6	Control Box	1	

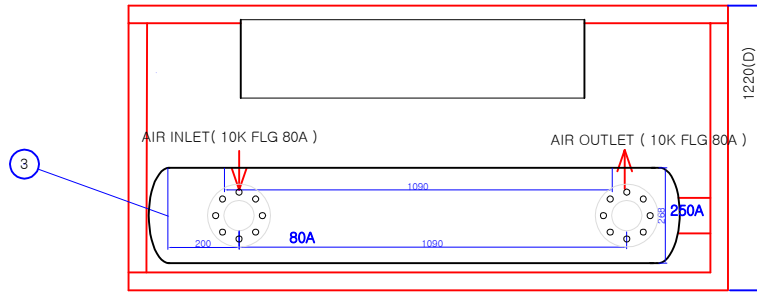

(Note) Refrigerant : HCFC-22(R-22)

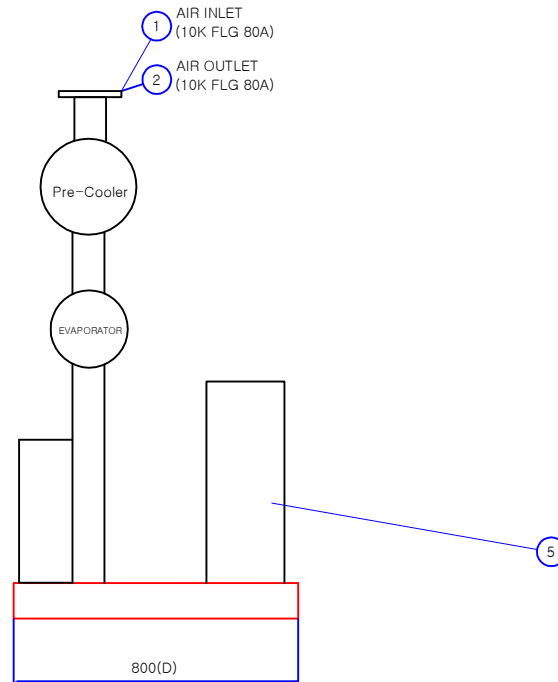
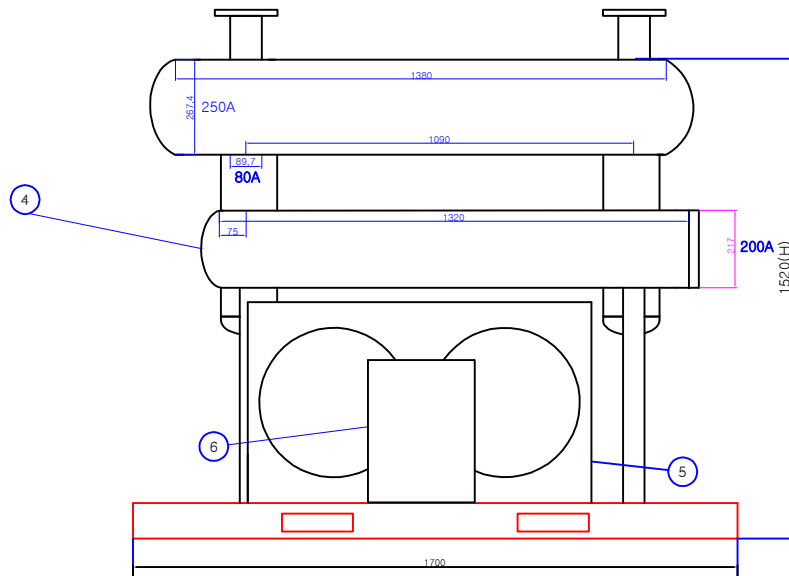

Outline Dimension for Tropical Air Dryer System	TAD-200 (200HP Class)	
	Edition	Sheet

A

B

C

D

E

F

A

B

C

D

E

F

1

2

3

4

5

6

7

8

1

2

3

6

7

8