

No.	Name	Q'ty	Description
1	Inlet Nozzle	1	Inlet Connection 10K FLG 200A
2	Inlet Filter	1	Fineness : 1 micron element
3	After Cooler	1	Hot Compressed Air-to-Cold Compressed Air HeatExchanger
4	PreCooler	1	Hot Compressed Air-to-Cold Compressed Air HeatExchanger
5	Evaporator	1	Compressed Air-to-Refrigerant HeatExchanger
6	Air-Cooled Condenser	1	
7	Outlet Filter	1	Fineness : 5 micron element
8	Outlet Nozzle	1	Outlet Connection 10K FLG 200A
9	Control Box	1	
10	Moisture Separator	1	

(Note) Refrigerant : HCFC-22(R-22)

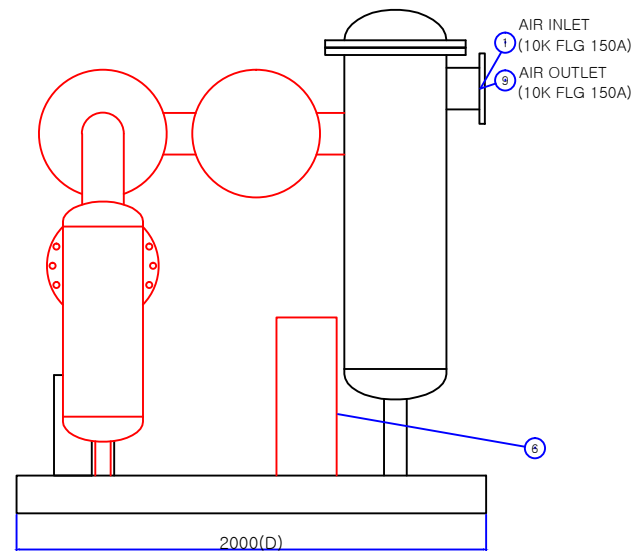
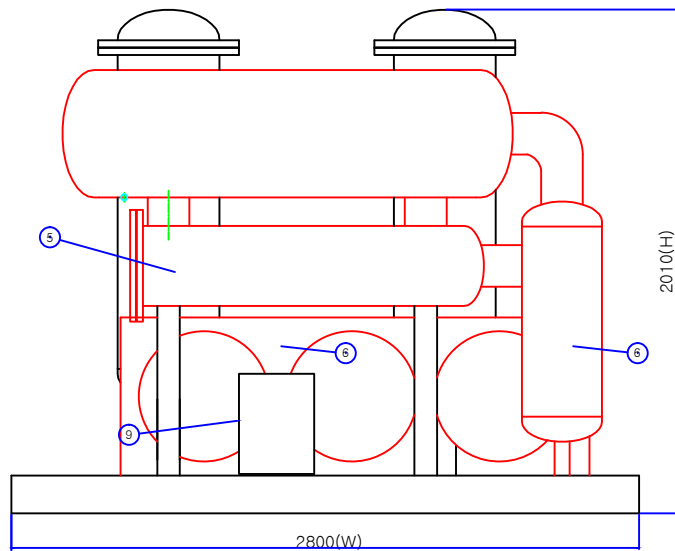

Outline Dimension for Tropical Air Dryer System	TAD-1000 (1000HP Class)	
	Edition	Sheet