

No.	Name	Q'ty	Description
1	Inlet Nozzle	1	Inlet Connection 10K FLG65A
2	Inlet Filter	1	Fineness : 5 micron element, Model No SJE-5-65A
3	After Cooler	1	Hot Compressed Air-to-Cold Compressed Air HeatExchanger
4	PreCooler	1	Hot Compressed Air-to-Cold Compressed Air HeatExchanger
5	Evaporator	1	Compressed Air-to-Refrigerant HeatExchanger
6	Air-Cooled Condenser	1	5HP, 0.1kW 6P x OD400 Fan x 2sets
7	Outlet Filter	1	Fineness : 5 micron element, Model No SJE-5-65A
8	Outlet Nozzle	1	Outlet Connection 10K FLG 65A
9	Control Box	1	

(Note) Refrigerant : HCFC-22(R-22)

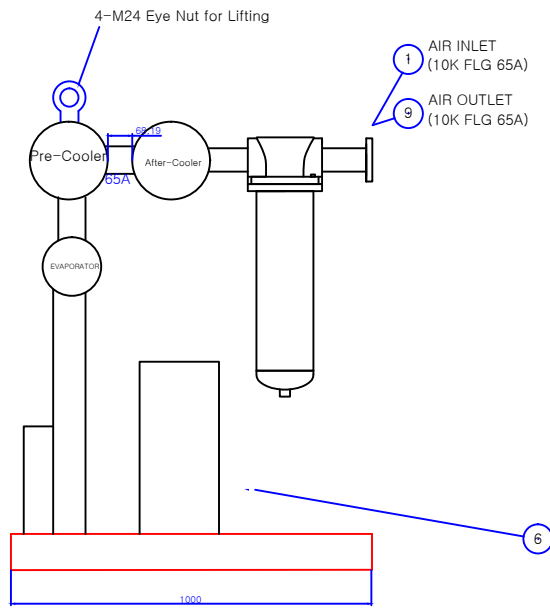
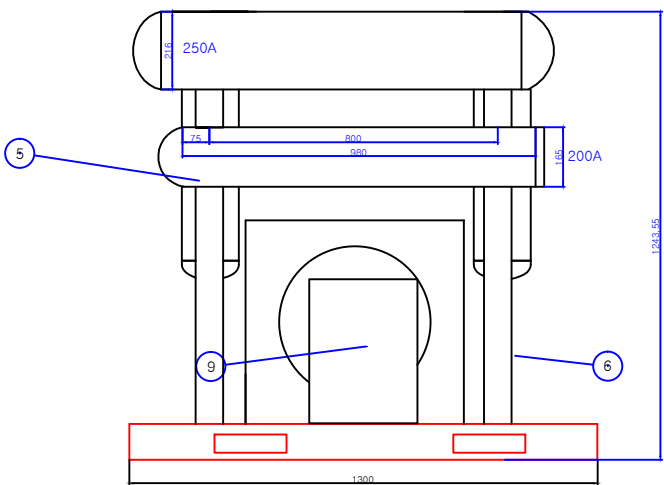

Outline Dimension for Tropical Air Dryer System	TAD-150 (150HP Class)	
	Edition	Sheet