

No.	Name	Q'ty	Description
1	Inlet Nozzle	1	Inlet Connection 10K FLG100A
2	Inlet Filter	1	Fineness : 1 micron element
3	After Cooler	1	Hot Compressed Air-to-Cold Compressed Air HeatExchanger
4	PreCooler	1	Hot Compressed Air-to-Cold Compressed Air HeatExchanger
5	Evaporator	1	Compressed Air-to-Refrigerant HeatExchanger
6	Air-Cooled Condenser	1	10HP
7	Outlet Filter(2nd)	1	Fineness : 0.01 micron element
8	Outlet Nozzle	1	Outlet Connection 10K FLG 100A
9	Outlet Filte(1st)	1	Fineness : 5 micron element
9	Control Box	1	

(Note) Refrigerant : HCFC-22(R-22)

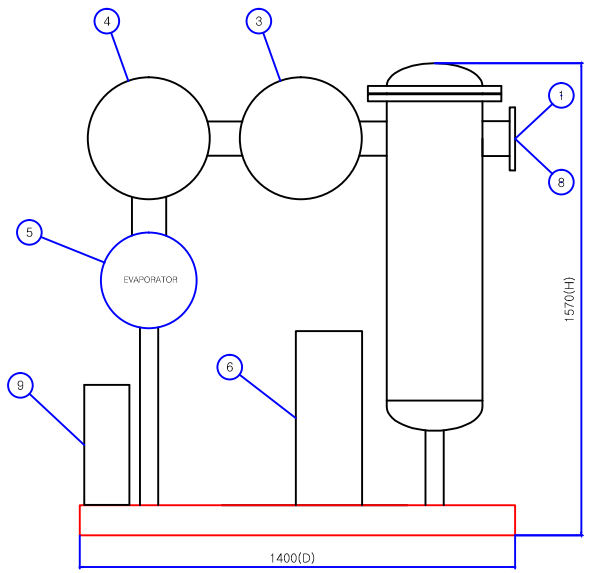
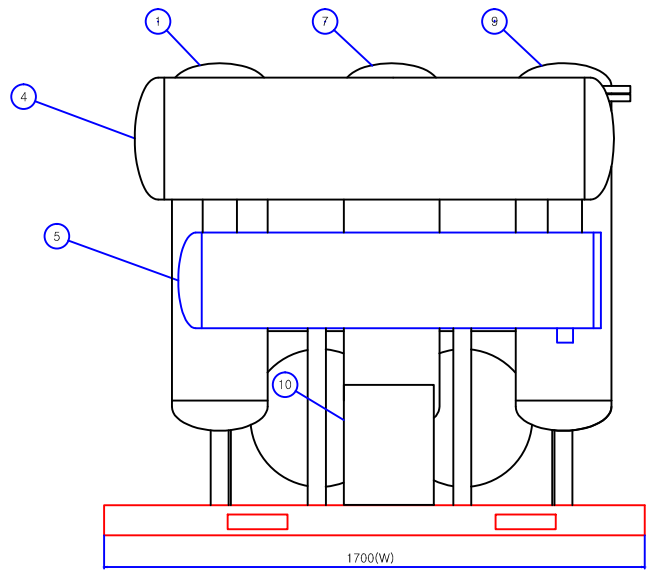

Outline Dimension for Tropical Air Dryer System	TAD-500 (500HP Class)		
	Air-Cooled Type	Edition	Sheet