

No.	Name	Q'ty	Description
1	Inlet Nozzle	1	Inlet Connection 10K FLG150A
2	Inlet Filter	1	Fineness : 1 micron element, Model No SJE-1-150A
3	After Cooler	1	Hot Compressed Air-to-Cold Compressed Air HeatExchanger
4	PreCooler	1	Hot Compressed Air-to-Cold Compressed Air HeatExchanger
5	Evaporator	1	Compressed Air-to-Refrigerant HeatExchanger
6	Air-Cooled Condenser	1	10HP, 0.75kW 4P x OD500 Fan x 2sets
7	Outlet Filter	1	Fineness : 5 micron element, Model No SJE-5-150A
8	Outlet Nozzle	1	Outlet Connection 10K FLG 150A
9	Control Box	1	

(Note) Refrigerant : HCFC-22(R-22)

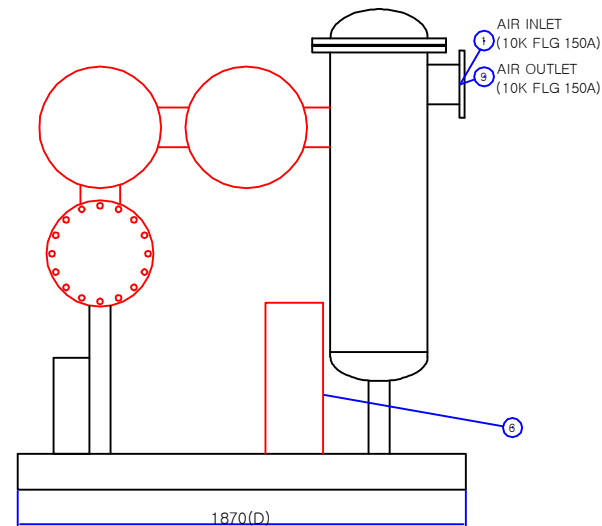
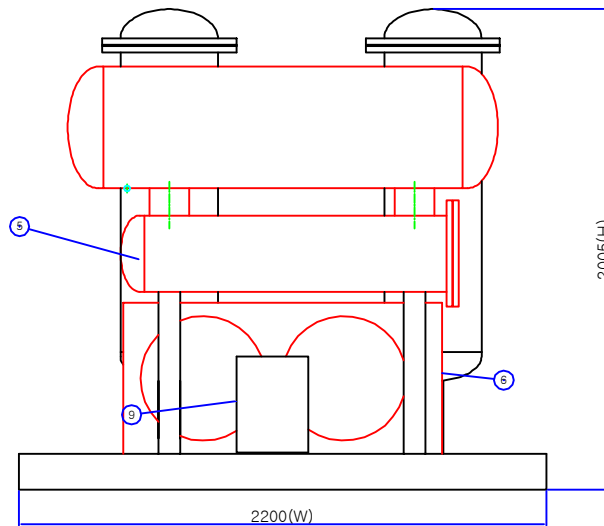

Outline Dimension
for
Tropical Air Dryer System

TAD-700 (700HP Class)

Edition Sheet